

Precaution

To avoid fire or electrical shock, do not expose this product to rain or moisture.

To avoid short circuit, please make sure the battery contacts are securely packed and in accordance with local provisions when handling the batteries.

Please place the batteries and the parts which can be swallowed mistakenly away from children. Contact a doctor immediately when it occurs.

To avoid possible injury to eyes, do not use the flash light in a short distance from the eyes.

To avoid possible safety accident, do not use the flash light on the people who need a high degree of attention.

If the following occurs, please take out the batteries and stop using them.

- This product is dropped or shocked seriously and the inner part of this product is bared.
- Wear gloves and take the batteries out if the corrosive liquid inside the batteries leaks.
- This product gives off strange smell, heat or smoke.

Do not disassemble or maintain this product because the internal high voltage circuit may cause the electric shock.

Please take out all the batteries if this product is not used for a long time.

Features

- **Supports Canon/Nikon optical transmission wireless slave flash**

One YN568EX III can respectively receive the wireless signal of master unit YN600EX-RT II, YN568EX II, YN568EX III, 600EX(II)-RT, 580EX II, SB-910/900/800/700, Nikon built-in flash C command and built-in wireless signal of Canon 7D/60D/600D cameras. It realizes wireless TTL, manual flash and stroboscopic flash.

- **GN58@ISO100, 105mm**

YN568EX III is high guide number TTL speedlite, which supports TTL, M, Multi flash.

- **Supports High-speed Sync**

Using YN568EX III can realize TTL and manual flash. The highest shutter synchronous speed is up to 1/8000s.

- **Supports Firmware Upgrade**

YN568EX III is equipped with USB port. You can download the upgrade firmware through the official YONGNUO website to update this speedlite.

- **Supports real-time display of battery remaining capacity**

The power capacity display function is newly added to YN568EX III. With this function, you can intuitively see the battery remaining capacity.

- **Ultrafast charging recycle system**

It takes just 2s for YN568EX III to finish charging recycle when it's used in full power. Although YN568EX III is not used with new batteries, the ultrafast charging recycle time is just 3s~4s.

- **Supports electric zoom**

YN568EX III supports auto zooming or manual zooming. The flash range can be adjusted from 24mm~105mm.

Contents

Precaution	1
Features	2
Quick Start	4
Components Description.....	5~8
Installation and Dismantlement Introduction	9
Basic Function.....	10~15
Advanced Applications	16~20
Wireless Flash Shooting.....	21~24
C.Fn: Custom Settings.....	25~27
Troubleshooting Guide	28
Specifications	29~30

Conventions used in this user manual:

- In order to learn and master the operation of this speedlite at the meanwhile you read this manual, please take the user manual of your camera as reference.
- In every operating step, we assume that both camera and speedlite are powered on.
- Icons used in this user manual
 - ☐ :Supplementary information
 - :Long press the button
 - ⚡ :Short press the button

Quick Start

If you don' t have much time to read the whole user manual, we advise you to read this section.

- 1.Please avoid the excessive use of the maximum power output. It can effectively extend the service life of this product. (It' s recommended to keep this speedlite idle for 10 minutes or more when entering overheat protection.)
- 2.Press each button to view the contents on the screen and learn the function.
- 3.Short press [MODE] button to switch flash mode: TTL/M/MULTI.
- 4.Long press [Fn] button to enter into custom settings.
- 5.Short press [ZOOM] button to enter into focal length settings or wireless parameter settings.
- 6.Long press [ZOOM] button to enter into trigger mode selection.
- 7.Press[UP], [DOWN], [RIGHT] and [LEFT] button to adjust the flash parameters. Some parameters should be selected firstly before adjustment.
- 8.In slave unit status, short press [Gr] button to enter group adjustment.
- 9.In slave unit status, long press [CH] button to enter into channel adjustment.
- 10.By pressing and holding [MODE] button and [Gr/CH] button, the flash shooting settings and wireless shooting settings will be restored to default.
- 11.In off status, pressing and holding [MODE] button, the speedlite turns on and enters into firmware upgrade interface.

Components Description

- 1.Reflector
- 2.Wide-angle diffuser panel
3. Flash head
4. PC port input
- 5.USB port
- 6.Access cover
- 7.Battery compartment cover
- 8.Wireless trigger sensor
- 9.off-camera indicator
- 10.AF assist beam
- 11.Lock-release knob
- 12.Hot-shoe stand
- 13.Sound port
- 14.Hot-shoe contact

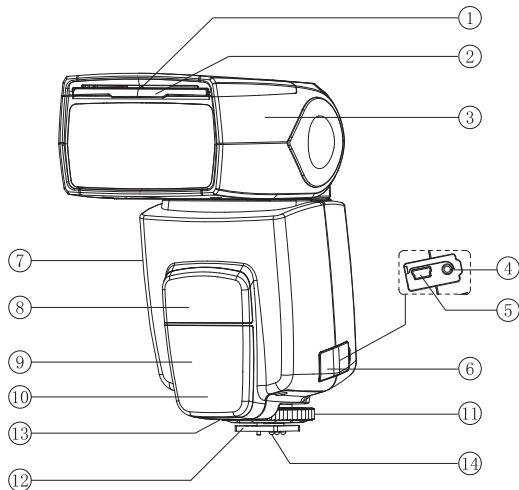

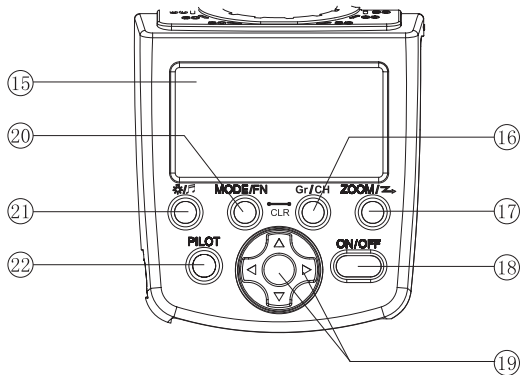

15.LCD display screen

17.Zoom button/Trigger mode button

19. Select/Set button

21.Backlight/Sound button

16.Group/channel button

18.Power switch

20.Mode/Custom setting button

22. Power recycle indicator/ Test button (Pilot)

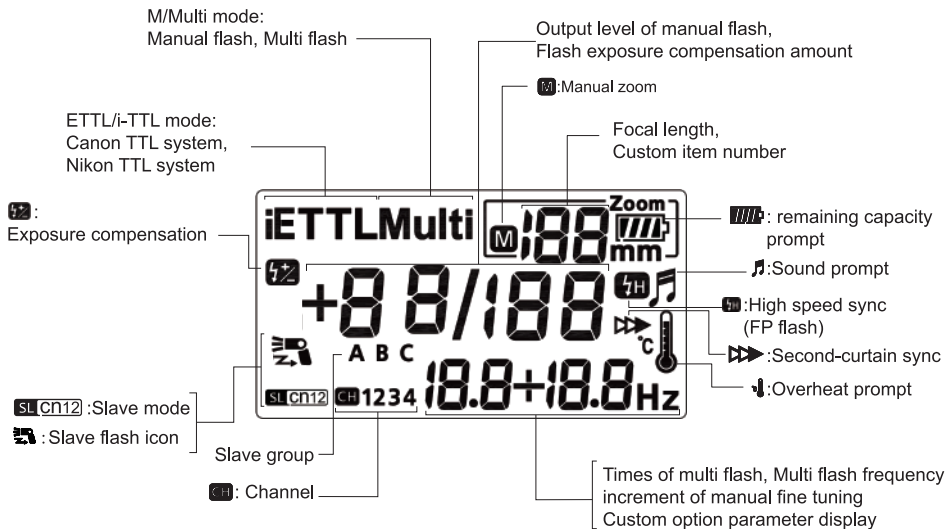

Power Recycle Indicator

Status of Indicator	Meaning	Method
Red light	The speedlite is fully charged and can be used.	Normal
Blue light	The speedlite has not been fully charged.	Waiting for completion of charging.
Blue light blinking	a.Low battery; the speedlite is about to shut down. b.Overheat prompt	a.Replace batteries. b. Reduce flash frequency or stop using the speedlite until it cools down.
Red light blinking	Overheat prompt	Reduce flash frequency or stop using the speedlite until it cools down.
Red light and blue light blinking	Overheat protection mechanism is activated.	Stop using the speedlite or shut down the speedlite until it cools down.

Sound Prompt

The Sound Mode	Meaning	Method
Tick twice	The sound indicator is enabled,the speedlite is started or flash is ok.	Normal.
Three ticks, two times	The exposure maybe excessive.	Adjust exposure compensation or shooting condition.
Tick tick tick	The exposure may be insufficient.	Adjust exposure compensation or shooting condition.
Tick-tick Tick-tick twice	The speedlite is in the charging.	Waiting for completion of charging.
Tick-a long sound .	The speedlite is fully charged, and can be used.	Normal.
Sound in rapid succession	The power is not enough and the speedlite is going to be shut down.	Replace the batteries.
Tick-tick-tick-	The speedlite is going to be shut down.	Restart the speedlite.

Installation and Dismantlement Introduction

1.Install Batteries

Slide the [battery compartment cover] in the direction of the arrow as shown. Insert the batteries according to the label inside the battery compartment and make sure the direction of the battery contact (+/-) is correct. Close the [battery compartment cover] in the direction of the arrow as shown.

 Please use 4pcs of AA batteries of standard specification. To avoid circuit, please do not use damaged batteries.

2.Attach the Speedlite to Camera

Rotate [Lock-release knob] to the highest point in the direction of the arrow as shown, slide the speedlite [Hot shoe stand] into the camera hot shoe, and tighten up the [Lock-release knob] in the direction as shown in the picture.

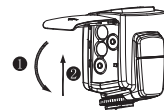
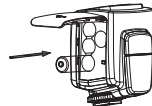
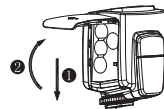
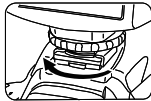

3.Dismantlement

To detach the speedlite, please release [Lock-release knob] and slide the speedlite out from the camera.

Basic Function

1. Power on and Power off

Long press [ON/OFF] button to turn on or turn off the power of the speedlite. It's recommended to turn off the speedlite before taking the batteries out.

After turned on, the <charging indicator> brights with red light which indicates it is ready to fire.

If the battery capacity is insufficient, the <charging indicator> brights with blue light. When the LCD screen displays the icon indicating the battery capacity is insufficient, the speedlite will shut down and the batteries need to be replaced.

After use, long press [ON/OFF] button to turn off the power of the speedlite.

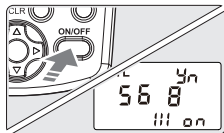

2. Test Flash

After the flash <charging indicator> turns into red, you can test the flash is normal or not by pressing [Pilot] button.

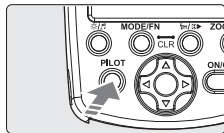

3. i-TTL Mode

Short press [MODE] button to adjust the flash mode to i-TTL mode. In i-TTL mode, the metering system of the camera can detect flash illumination reflected back from the object so as to automatically adjust the exposure compensation; the subject and the background will get equal exposure. Functions, like exposure compensation, exposure bracketing, high-speed sync,

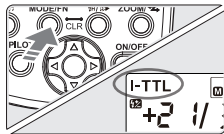

second-curtain sync, exposure lock, modeling light, are supported.

In i-TTL mode, you can set exposure compensation for flash. The range of flash exposure compensation is -3EV~+3EV. The precision is 1/3EV.

4.M mode

Short press [MODE] button to set the flash mode to M mode. In M mode, the flash output can be adjusted according to your own need, short press [up] [down] [left] [right] to adjust the flash output of the speedlite. The setting range of the flash output in M mode is 1/128~1/1, the output can be divided into 8 grades, each grade can be divided into 3 grades of fine adjustment at most, with 1/3EV as adjustment increment, there are 22 grades for fine adjustment totally. Press [Left] [Right] for adjustment of flash output, short press [up] [down] for fine adjustment, the outcome will be displayed on the LCD screen. When shooting, you only need to set the flash output, set the camera and press camera shutter, the speedlite fires under synchronous signal of the camera.

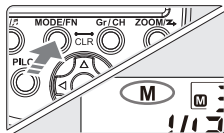

5.MULTI Mode

Short press [MODE] button to set the flash mode to Multi (stroboscopic) mode. In Multi mode, the speedlite fires according to the selected flash output, flash frequency and number of flashes. The setting method of flash output is the same as that of M mode, setting range of flash output is

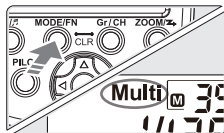

1/128-1/64-1/32-1/16-1/8-1/4。 Short press **【OK】** to select number of flash,short press **【OK】** again to select frequency,after selecting the parameters,press **【left】** **【right】** to adjust number of flash and flash frequency.The setting range of number of flash and flash frequency are both 1 ~ 100.When the number of flash is set to <---->,it means the flash will fire continuously until the shutter closes or the battery runs out.

 When the speedlite is in low battery, the charging speed is slow. It possibly causes missing flash when the speedlite fires with high frequency. In this situation, please reduce flash frequency and replace with new batteries.

6.ZOOM: Set the flash range

Auto Zoom: short press the **【ZOOM】** button until the focal length value displays on LCD panel,then adjust the coverage through the [Left] and [Right]button. When it does not displays<M> in the left of the <ZOOM> icon,attach the speedlite to the camera,the flash coverage will change as the lens focal length and move back and forth to accommodate different flash coverage (the default is 35mm).

Manually Set the zooming position: Press [ZOOM] button to select focal length value, and adjust the focal length value with [RIGHT] or [LEFT] button. When <M> displays at the left side of [ZOOM] icon, the flash coverage (24, 28, 35, 50, 70, 85, 105mm) can be manually adjusted.

 When using wide-angle diffuser, the flash coverage will be extended to 14mm and the focal length will be locked.

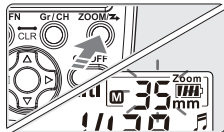

7.AF -Assist Beam

When it is difficult to autofocus on the subject in low-light or low-contrast shooting environment, the speedlite will activate the built-in AF-Assist Beam to help the camera autofocus,the AF-Assist Beam can be set to be enable or disable through the custom function of the speedlite or camera.

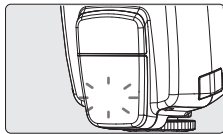

 When using this function,the focus mode of the camera should be set to AF-S or AF-A,otherwise the assist beam might not work.

8.Modeling Flash

When the camera' s aperture preview button is pressed,the flash fires continuously for approx.1 second,this feature is called “Modeling Flash” .For detailed operation,please refer to the user manual of the camera.

 Please try to keep the times of continuous modeling flash within 10 in case of the excess temperature or burn out of the flash.

9.Power Saving Mode

This product is designed with power saving mode,and the power saving mode can be achieved by custom function setting,for detailed settings,please refer to subsequent “custom function setting” chapter.When the power saving mode is on ,the flash keeps idle for a while and go to sleep,in sleeping mode,the flash keeps idle for a while and powers off automatically.If the flash is in sleeping mode,you can half press the shutter of the camera or press[Pilot]to wake up the flash.

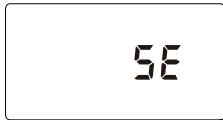

10.Overheat Protection

Sequential flash causes the increase of the internal temperature of the speedlite,when the temperature reaches to a certain amount,the overheat warning of the speedlite appears.

If the speedlite is used too frequently,the overheat protection will be triggered,and the LCD screen shows the icon of <overheat protection>,with red and blue light of [recycling indicator light] flashing alternatively.When the overheat protection is triggered,the speedlite will be locked, the parameter cannot be adjusted and the speedlite cannot fire.In this case,please keep the speedlite idle for over 10 minutes until the speedlite cools down for continual use.In order not to affect shooting,please try to use 1/4 output or lower output level when fast shooting is needed.

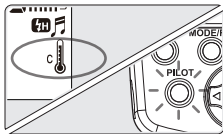

Overheat warning



Overheat protection



When the speedlite is used frequently, the flash recycling time will be extended.

When overheat warning icon is displayed, please reduce the flash rate or flash output.

After continuous shooting, please mind the overheated batteries when take them out from the battery compartment.

11.Sound Prompt Function

Through the C.FN06 option of custom function setting,you can turn on or off the sound prompt function.When this function is on,the speedlite will make different sounds to remind the working mode,for the specific sound method and meaning,please refer to "Component Description chapter.

12.PC Sync Port

The speedlite fires synchronously through 2.5mm PC Sync Port.

13.Automatic Setting Saving

When the power is turned off through power switch ,the speedlite will save the current settings automatically ,which is convenient for your next use.

14.Clear Settings

Press the [MODE] and [Gr/CH] at the same time for about 2 seconds, apart from the custom function setting, the parameters such as the trigger mode, flash mode, flash output and focal length will be restored to default setting.



For restoring the custom function setting, please refer to custom function setting chapter.

15.Firmware Upgrade

This product supports firmware upgrade, please visit YONGNUO official website www.hkyongnuo.com to download the latest update software and firmware to upgrade the speedlite. The upgrading method is as follows,

- Connect with the PC through USB cable (USB cable is required to buy separately).
- Turn off the speedlite, press [MODE], then press [ON/OFF] to turn on the speedlite and enter the upgrade interface.
- Enter upgrade software, upgrade the speedlite according to the software prompts.

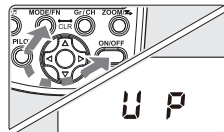
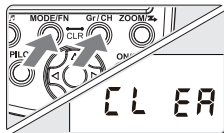

Advanced Applications

1.High-speed Sync (FP)

With high-speed sync flash(FP flash),the speedlite can be synchronized with all shutter speeds,the maximum shutter sync speed is up to 1/8000s.High-speed synchronization makes it very convenient to shoot in aperture-priority to fill flash for portrait. High-speed sync function should be turned on through the camera,which means this function works normally only if it is supported by the camera.For specific setting method,please refer to your camera user manual.When the function is on,the high-speed sync icon will be displayed on the LCD screen.

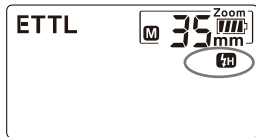

2.Second-curtain Sync

With Second-curtain Sync,the speedlite fires at the moment that the shutter is closing.Using slow shutter speed and second-curtain sync produce the trail of light source of the subject.The second-curtain sync function needs to be supported by the camera itself,for the setting method,please refer to the user manual of the camera.When the second-curtain sync is on,the LCD screen shows the icon of second-curtain sync.

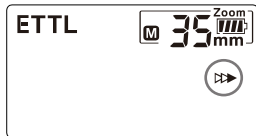

3.Remote Wireless Flash

YN568EX III supports remote wireless flash,the longest distance is 25 meters for indoors,15 meters for outdoors.

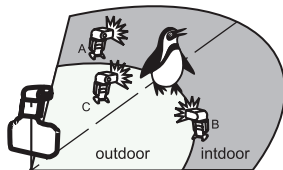

 In shooting with optical transmission wireless flash,when the flash is in Sc/Sn trigger mode,the flash mode ,flash output and synchronization method of the slave unit are fully controlled by the master control unit.

4、 Flash Exposure Compensation

In order to make the shooting effect more satisfactory,you can set the flash exposure compensation on the camera menu or on the speedlite.The settable range of the flash exposure compensation is $-3EV \sim +3EV$, the increment of exposure compensation level is $1/3EV$.Short press the [RIGHT] or [LEFT] button to set the exposure compensation value directly,press [OK] to save setting.

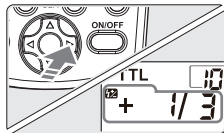

 When the exposure compensation are set on flash,camera and flash trigger all at once ,the value of compensation will be added.

5.Flash Exposure Bracketing

You can set the exposure bracketing on the speedlite or on the camera. When the exposure bracketing is set, for every 3 photos, a certain amount of positive or negative compensation will be made automatically, and in the sequence of , for example, “normal→under→over” . This function will increase the success rate of your photography.



When using FEB, it is recommended to set the camera's drive mode to “single shooting” , and please make sure the speedlite has been fully recharged before shooting with FEB.

6、 FE lock (Canon)

With FE lock, you should use the center of camera's viewfinder to cover the flash-exposed subject which needs to be locked, press the flash exposure lock button [*] of the flash, the speedlite will fire a preflash and the camera will calculate the suitable output level, at this time you have some time to recompose, after that, just press shutter to shoot. (This function can be used only when it is supported by the camera itself, for the setting, please refer to the user manual of your camera.)

7.FV Lock (Nikon)

When use this function, please set “AE-L/AF-L” function as “FV Lock” . At this time, you can aim at the object in the viewfinder and then press the [AE-L key/AF-L key], in such case, the speedlite will pre-flash to get the reading of flash exposure for the object. After you confirm the scene frame, press the shutter to take photos. (This function can only be used when it's supported by your camera. For the setting of AE-L and AF-L please refer to the user manual of your camera.)

8.High-speed Continuous Shooting

This product supports high-speed continuous shooting,please set continous shooting mode on the camera before shooting.

 The quantity of photos of continuous shooting depends on the flash output setting,please use the batteries with sufficient electricity.

9.Reflection Flash

Refecation flash means using flash head aiming at the wall or ceiling,illuminate the subject with the help of reflected light for shooting.(commonly known as “bounce flash”, which can decrease the shade behind the subject for more natural shooting effect.

If the wall or ceiling is out of distance,the bounce flash may be too weak to get enough exposure.The wall or ceiling should be flat and white ,which helps to get efficient reflection,if the reflecting surface is not white,color cast may appear on the photo.

10.Use reflection board for shooting

Using reflection board for flash,pull out reflection board and wide panel at the same time from the flash head and push back the wide panel.If you take photo as this time, a highlight will be produced in the person' s eyes,which makes the eyes more charming(catchlight).It is most effective when you position the flash

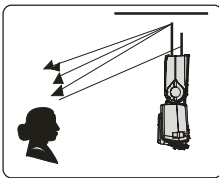
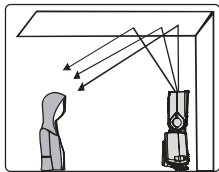

head toward the front and 90° up.

11. Use Wide-angle diffuser panel

Pull out the wide-angle diffuser panel ,push back the reflection board ,and place them according to the picture,the flash range will be increased and the flash effect will be softer and more natural.



Using the wide-angle diffuser panel,the flash range will be increased and locked at 14mm.

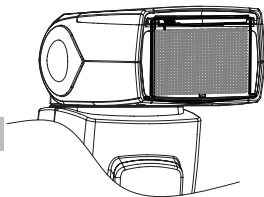

Wireless Flash Shooting

YN568EX III can be used as slave unit in wireless radio transmission flash shooting. When it is used as a slave unit, YN568EX III supports Sn、Sc、S1、S2 four off-camera trigger modes. The effective distance of wireless radio transmission flash shooting is: indoor 25 meters, outdoor 15 meters.



When in wireless flash shooting, the wireless sensor of the slave unit should face the master unit, and make sure the slave unit is within the effective flash distance of the master unit.

Please do not place any barrier between the master unit and slave unit, otherwise it may disturb the wireless flash signal transmission.

1. Sn/Sc Off-camera Trigger Mode

When YN568EX III is used as a slave unit and the Sn/Sc off-camera trigger mode is selected, it can respectively accept internal flashing of YN600EX-RT II、YN568EX II、600EX (II) -RT、580EX II、7D/60D/600D, C-commander of N' s camera build-in flash to achieve wireless TTL and manual flashing, which is easy to realize off-camera TTL、M、Multi flash.

In Sn/Sc off-camera trigger mode, the YN568EX III supports three grouping settings (A/B/C) ,and total four channels (CH1/2/3/4) for option.

•Master Unit Setting

The master unit can choose the internal flashing of YN686EX-RT、YN600EX-RT II、YN568EX III(II)、580EX II、600EX II、7D/60D/600D, C-commander of N' s camera build-in flash, SU-800、ST-E2 and etc. The relevant settings please refer to the user manual of the master unit you use.

•Slave Unit Setting

Long press the <ZOOM> button to enter into the trigger mode select statue, short press the [Left] or [Right] button to select the trigger mode is Sn or Sc.

Sc trigger mode: only receive the optical transmission wireless flash signal of Canon system

Sn trigger mode: only receive the optical transmission wireless flash signal of Nikon system

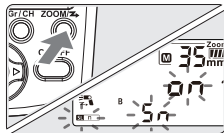

•Channel Setting

On the slave unit YN568EX III, long press the [CH] button until the <CH> icon blink, then press the [Left] or [Right] button to adjust the channel (CH1/2/3/4), press the [OK] button for save.

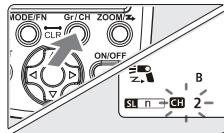

 In the wireless radio transmission flash shooting process, make sure the channel of the master unit and slave unit are the same, otherwise it could not flash.

•Grouping Settings

On the slave unit YN568EX III, short press the [Gr] button to choose the off-camera grouping (A/B/C) directly.

•Flash mode and expose parameter settings of the slave unit

When the YN568EX III work in Sc or Sn trigger mode, the flash mode and output of slave unit will be completely controlled by the master unit.

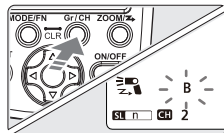

•Use multiple slave units for wireless flash shooting

Set the slave unit from one of the group A,B,C.

Set the channel of the master unit and slave unit are the same,then set the flash ratio to ALL、 A:B、 A:B C (or RATIO A:B:C) .Press the test button of master unit to test the flash if normal.If the slave unit does not flash,please check if the angle and distance of the YN568EX III to the master unit meet the requirement or not.



When set to <RATIO A:B>, the slave unit set as group C, the group C of slave unit will not flash.

If you need A、 B、 C three groups of flash at the same flash output, please make the flash to<RATIO OFF>.

If you need larger output or hope for better lighting,you can increase the number of flash on one slave group.

For example: if the three slave units set to group A,they will be seen as one speedlite and controlled by the master unit.

2.S1/S2 trigger mode

S1/S2 trigger mode is respectively suitable for the manual flash environment and TTL flash environment.When the YN568EX III in S1/S2 trigger mode, the flash mode will default to M mode, the setting method of flash output is the same as set top M mode.

S1 mode: In this mode it will work with the first flash synchronously of the master flash, with the result consistent with the use of radio slave. To use this

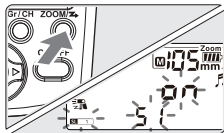
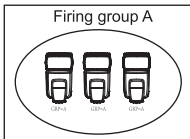

mode properly, the master flash should be set to manual flash, should not use the TTL flash system with pre-flash function and the red eye reduce function with multiframe.

S2 mode: It is also called “pre-flash cancel mode” . This mode is similar with S1 mode, but it can neglect the pre-flash given by TTL flash. Therefore, it can support the master flash working in TTL mode. In particular, if S1 mode cannot flash properly and synchronously with your internal flash, you can try to use S2 mode.



The following situation shall be avoided when the S1 and S2 modes are used: the red eye reduction function of the main light is used; the order mode (Nikon) or wireless mode (Canon) of the main light is used; the ST-E2 is used as the flash controller. Otherwise, it may lead the flash out of sync.

C.Fn:Custom Function Setting

You can custom the flash function according to your requirement. Long press the function button [Fn] to enter the custom function menu, short press the [Up] or [Down] button to select the custom function item(Number,such as C.Fn 01),short press the [Left] or [Right] button to enter the submenu,short press the [OK] button to save settings and exit the submenu. Select the custom item C.Fn E4,long press the [OK] button will restore to the custom function to factory default.

Custom Function supported by YN568EX III is as following:

Fn number 01

SL EP on: Turn on the power saving mode

SL EP --: Turn off the power saving mode

Fn number 02

AF on: Turn on the AF-assist beam

AF --: Turn off the AF-assist beam

Fn number 03

FULL F: Supports Full-frame model focal length coverage

AP S C: Supports APS-C model focal length coverage



Fn number 04

SL Sd 10: the slave unit will go to hibernation after idle for 10 minutes

SL Sd 60: the slave unit will go to hibernation after idle for 60 minutes

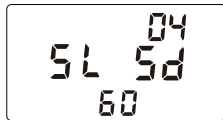
**Fn number 05**

SL oF 1H: Slave auto power off within 1 hours hibernation

SL oF 8H: Slave auto power off within 8 hours hibernation

**Fn number 06**

So nd on: Turn on sound prompt

So nd --: Turn off sound prompt

**Fn number: E1**

SE oF 3/5/10/30/1H/2H/3H/4H/5H: Respectively indicates the flash will hibernate when idle for 3 minutes / 5 minutes/ 10 minutes / 30 minutes / 1 hour / 2 hours / 3 hours / 4 hours / 5 hours, and then automatic shutdown if continuous hibernate for the same time.

SE oF --: No hibernation, no shutdown.

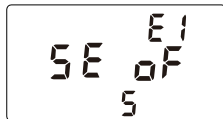

Fn number: E2

qu ic - -: Shut down the quick power on/off function (default)

qu ic on: Turn on the quick power on/off function

Fn number: E3

L cd 7/15/30: The display time of LCD backlight is 7/15/30 seconds

Fn number: E4

CL EA - -: Restore the advanced options the default Settings (Long press the OK button will restore the default settings)

Fn number: E5

Display the information of current version for the flash.

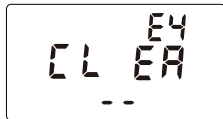
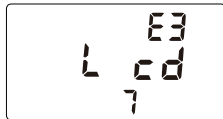
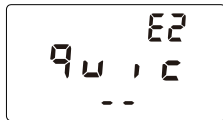

Troubleshooting Guide

1.Unable to turn on the power source or unable to flash

Please check whether the battery is installed correctly and with enough electricity;and please ensure that the flash hot shoe properly installed on the camera hot shoe and the flash knob lock fixed.

2.It could not flash in optical transmission wireless flash shooting.

When using outdoors, please avoid direct sunlight to the flash wireless sensor;Ensure the master unit and the slave unit channel set to consistent, and the slave unit is located in the effective wireless transmission range of the master unit.

3.Photo underexposure or overexposure

Check if the current camera shutter, aperture, sensitivity (ISO) is too close to the limit of the flash, or if the exposure compensation, exposure bracketing and relevant settings on the camera and flash are correct.

4.The photos appear dark corners or subject object can only partial light up.

Please check the current flash coverage;Please check whether the lens focal length is beyond the range of the flash, if excess you can try to pull out the wide panel to enlarge the coverage of the flash.

5.The flash control panel display blurred.

There is a layer of film on the screen when it out of the factory, you can tear it to enjoy more clear visual effect.

6.Other problems of the flash.

Please try to clear the settings of the flash and camera,or turn off and on the flash and camera.If the problems still exist,please contact YONGNUO After-Sale Service Hot line 400-0013-888 or email to service@hkyongnuo.com for help.

Specifications

Circuit design	Insulated Gate Bipolar Transistor (IGBT)
Guide No.	58 (ISO 100, 105mm)
Flash mode	TTL,M, Multi
Trigger mode	Set-top,wireless optical slave (Sc, Sn, S1, S2)
Zoom range	24, 28, 35, 50, 70, 85, 105
Vertical rotation angle	-7~90 degrees
Horizontal rotation angle	180 degrees each side
Power supply	4×AAsize batteries (Alkaline or Ni-MH are usable)
Lighting times	100~1500 times (AA alkaline cell used)
Recycle time	Approx 2 seconds
Color temperature	5600k
Flash time	1/200s~1/20000s
Flash control	8 levels of output control (1/128~1/1), 22 levels of fine tuning
External interface	hot shoe, PC port,USB port
Optical transmission triggering distance	indoor 20~25meters,outdoor 10~15meters
Additional features	off-camera flash,high-speed sync, second-curtain sync, FEC, FEB, FEV, the electronic flash head zooming, sound prompt, automatically saving setting, power saving mode, overheat protection,custom function,firmware update
Dimensions	62×72×188mm (Extended state)
Net weight	430g
Contains items	Speedlite(1), protecting bag (1), mini stand (1) ,manual (1), manufacturer certificate(1)

Guide Number (ISO 100, in meters / feet)

Flash Output	Flash Coverage (mm)							
	14mm	24mm	28mm	35mm	50mm	70mm	80mm	105mm
1/1	15/49.2	28/91.9	30/98.4	39/127.9	42/137.8	50/164	53/173.9	58/190.3
1/2	10.6/34.8	19.8/65	21.2/69.6	27.6/90.7	29.7/97.4	35.4/116.1	37.5/123	41/134.5
1/4	7.5/24.6	14/45.9	15/49.2	19.5/64	21/68.9	25/82	26.5/86.9	29/95.1
1/8	5.3/17.4	9.9/32.5	10.6/34.8	13.7/45.2	14.8/48.6	17.7/58.1	18.7/61.4	20.5/67.3
1/16	3.8/12.5	7/23	7.5/24.6	9.7/32	10.5/34.4	12.5/41	13.3/43.6	14.5/47.6
1/32	2.7/8.9	4.9/16.1	5.3/17.4	6.9/22.7	7.4/24.3	8.8/28.9	9.4/30.8	10.3/33.8
1/64	1.9/6.2	3.5/11.5	3.8/12.5	4.9/16	5.3/17.4	6.3/20.7	6.6/21.7	7.3/24
1/128	1.3/4.3	2.5/8.2	2.7/8.9	3.5/11.4	3.7/12.1	4.4/14.4	4.7/15.4	5.1/16.7

The electronic version manual can be downloaded from www.hkyongnuo.com.

The functions of this manual are based on the test conditions of our company. Further notice will not be given if the design and specifications change;

The YONGNUO logo in this manual includes the registered trademark or trademark of **SHENZHEN YONGNUO PHOTOGRAPHY EQUIPMENT Co., Ltd** in China or/and other countries (regions). All other trademarks are the property of their respective owners.